

□60
60W

Product Features

- Minimize vibration and noise
- Minimize cogging load
- Protection against heat
- A variety of drive controller option



DIMENSIONS

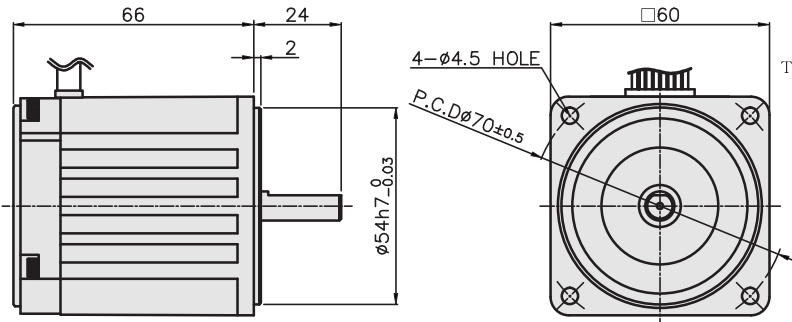

CHARACTERISTIC CURVE

Model No. : HBM6-6024A

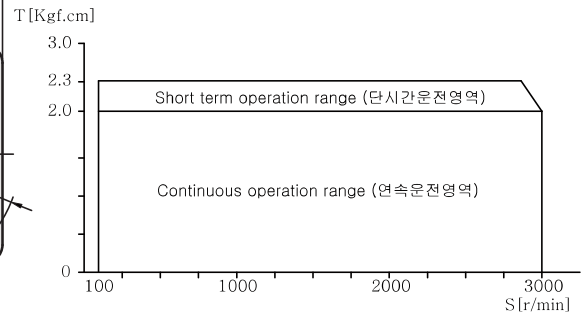

MOTOR OUTPUT SHAFT

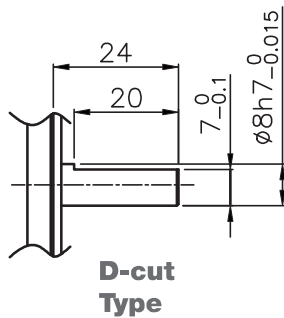

CIRCUIT DIAGRAM

LOW VOLTAGE

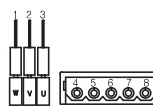

NO	COLOR	SIGNAL
1	ORANGE	W
2	GREEN	V
3	BLUE	U
4	RED	VCC
5	BLACK	GND
6	WHITE	H3
7	BROWN	H2
8	YELLOW	H1

HIGH VOLTAGE

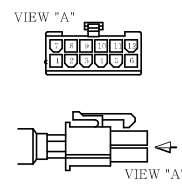

NO	COLOR	SIGNAL
1	ORANGE	W
2	-	-
3	-	-
4	YELLOW	H1
5	BROWN	H2
6	WHITE	H3
7	GREEN	V
8	BLUE	U
9	BLACK	EARTH
10	-	-
11	RED	VCC
12	BLACK	GND

SPECIFICATION

Model	Output (W)	Voltage (VDC)	At Rated Load			Weight (kg)
			Speed (rpm)	Torque (kgf-cm)	Current (A)	
HBM6-6024A	60	24	3000	2.0	4.00	0.64
HBM6-60310A	60	310	3000	2.0	0.35	0.64