

□ 60 10W, 15W, 30W



FEATURES

- Low Price & Slim Size Design
- High Efficiency
- Small size & Light Weight
- A wide range of application

DIMENSIONS

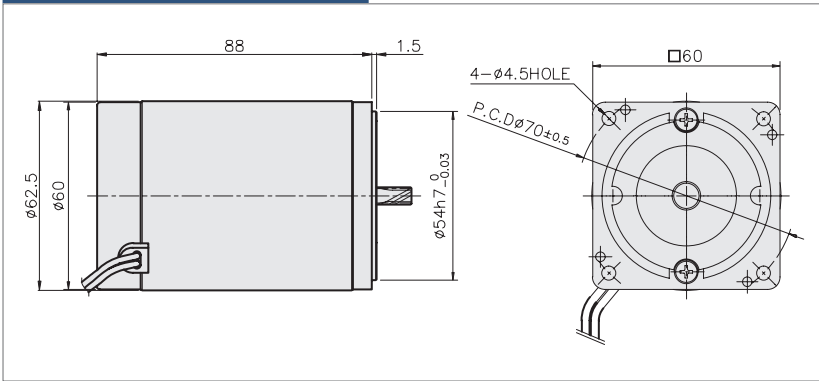

CHARACTERISTIC CURVE



MOTOR OUTPUT SHAFT

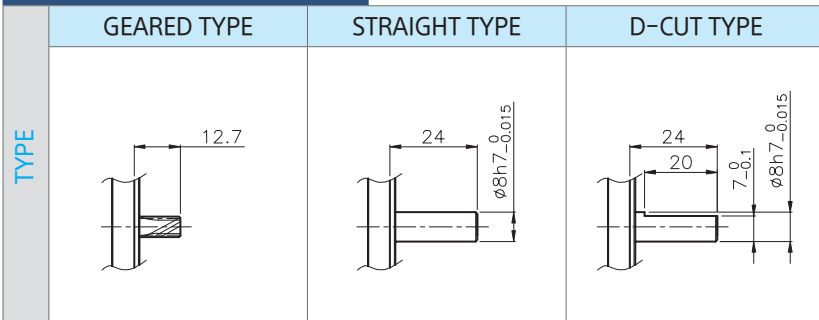

CIRCUIT DIAGRAM

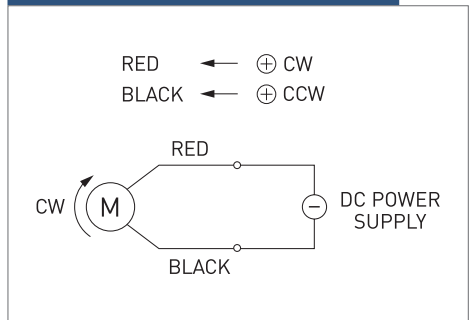

SPECIFICATION

Model	Output (W)	Voltage (V)	No-Load		At Rated Load			Weight (kg)
			Speed (rpm)	Current (A)	Speed (rpm)	Torque (kgf.cm)	Current (A)	
HM6-1012A	10	12	3300	0.8	2950	0.33	1.3	0.8
HM6-1024A		24	3300	0.6	3000	0.33	0.7	
HM6-1512A	15	12	3200	1.0	2900	0.50	2.4	0.8
HM6-1524A		24	3400	0.5	3100	0.50	1.2	
HM6-3024A	30	24	3400	0.7	2900	1	2.4	0.8