

□ 80 25W, 60W, 90W

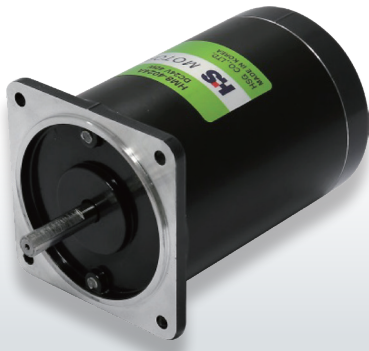

FEATURES

- High Efficiency
- Low noise & Low Vibration
- A wide range of applications

DIMENSIONS

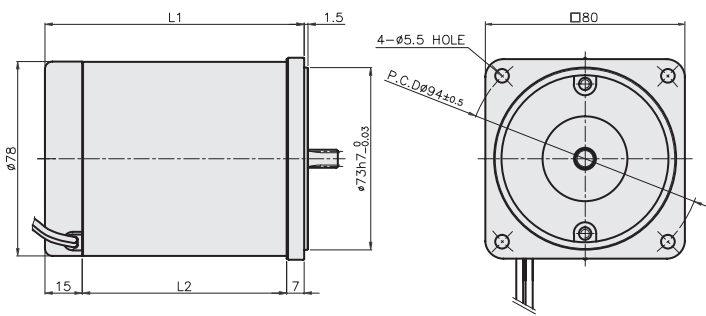

CHARACTERISTIC CURVE

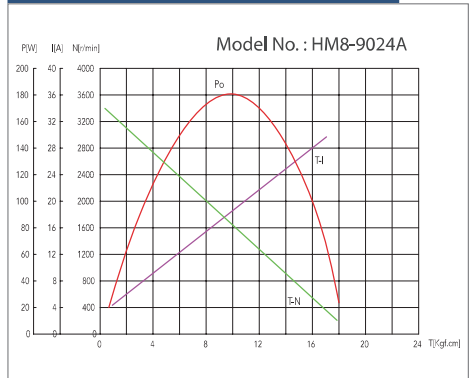

MOTOR OUTPUT SHAFT

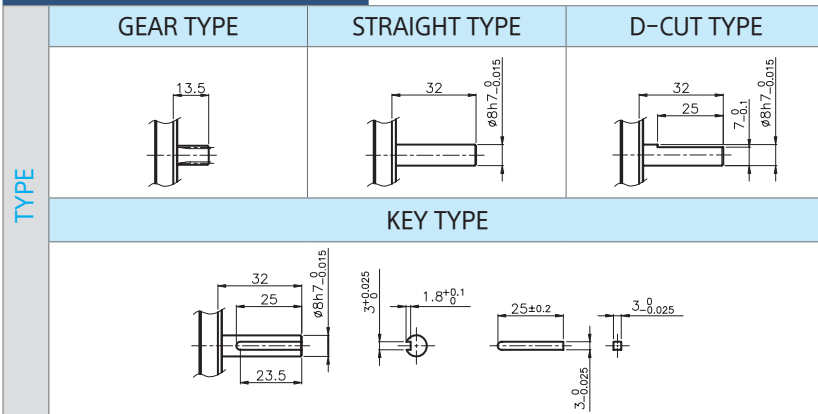

CIRCUIT DIAGRAM

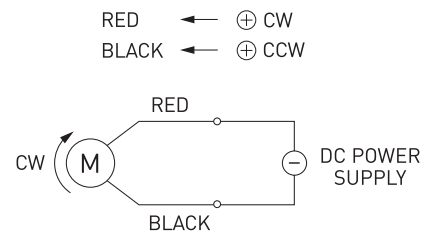

SPECIFICATION

Model	Output (W)	Voltage (V)	No-Load		At Rated Load			Weight (kg)	Motor Length (L1/L2)
			Speed (rpm)	Current (A)	Speed (rpm)	Torque (kgf.cm)	Current (A)		
HM8-2524A	25	24	3300	0.8	2900	0.8	2.0	1.6	104/82
HM8-6024A	60	24	3500	1.2	3100	2	3.3	1.6	114/92
HM8-9024A	90	24	3300	1.2	2900	3	5.0	1.7	