

□ 90 150W, 200W

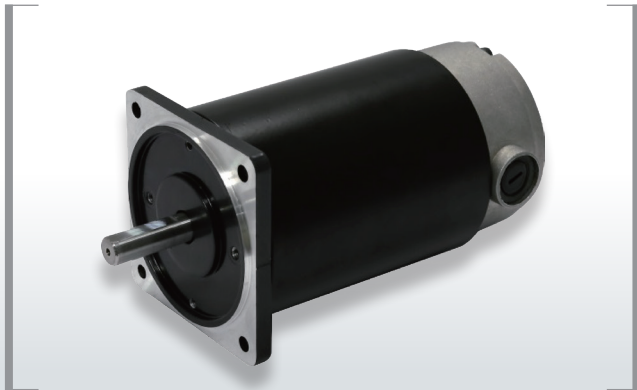

**FEATURES**

- High Efficiency
- Low noise & Low Vibration
- Replaceable brushes

**DIMENSIONS**

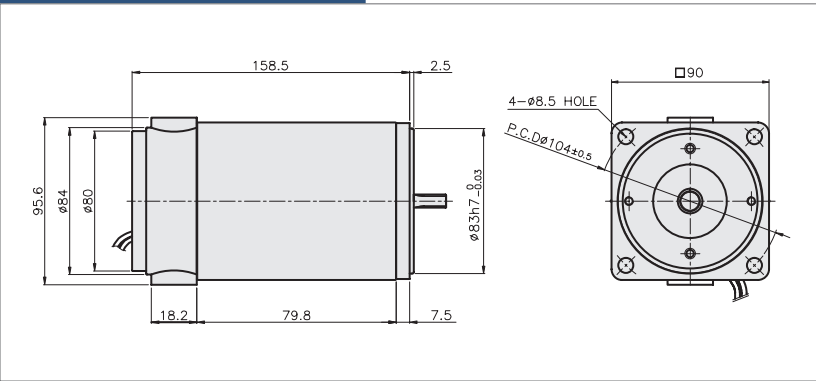

**CHARACTERISTIC CURVE**

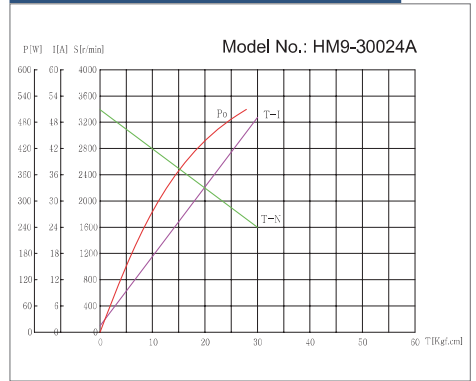

**MOTOR OUTPUT SHAFT**

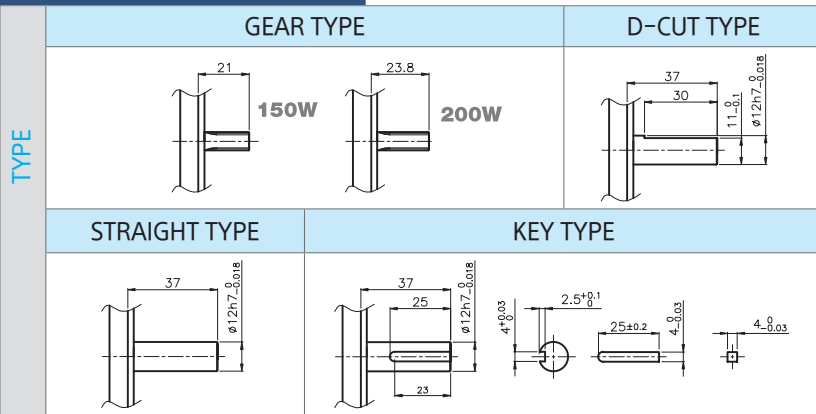

**CIRCUIT DIAGRAM**

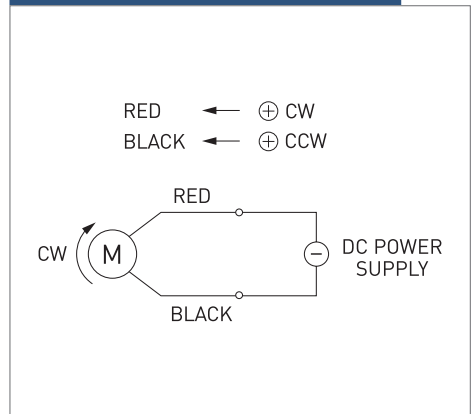

**SPECIFICATION**

Model	Output (W)	Voltage (V)	No-Load		At Rated Load			Weight (kg)
			Speed (rpm)	Current (A)	Speed (rpm)	Torque (kgf.cm)	Current (A)	
HM9-15024A	150	24	3200	1.5	2900	5	8.8	3.4
HM9-20024A	200	24	3400	1.5	3000	6.5	11.2	3.4