

□ 60 60W

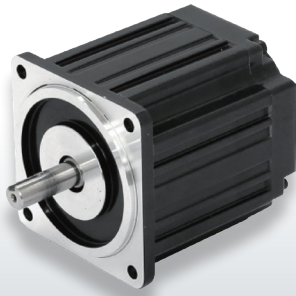

FEATURES

- Minimize vibration and noise
- Minimize cogging load
- Protection against heat
- A variety of drive controller option

DIMENSIONS

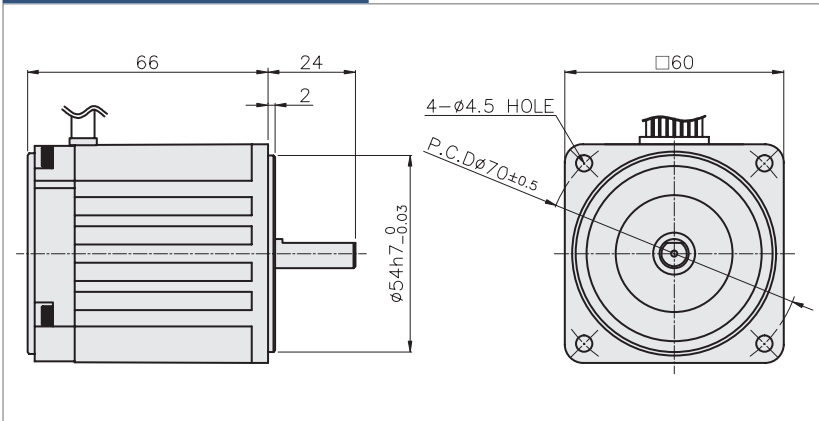

CHARACTERISTIC CURVE

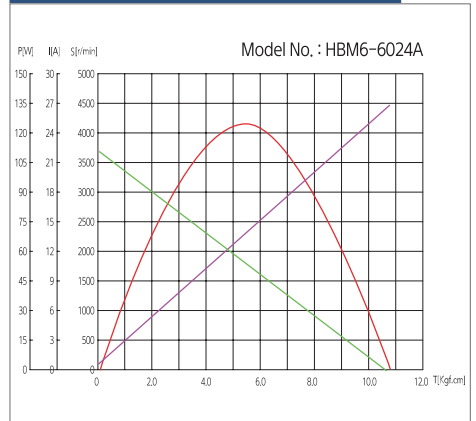

MOTOR OUTPUT SHAFT

D-CUT TYPE

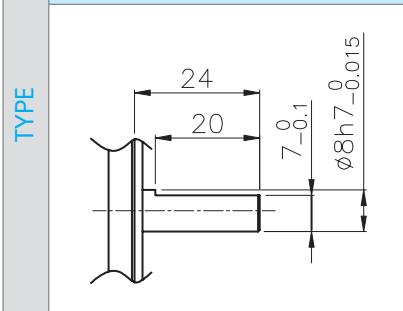

CIRCUIT DIAGRAM

LOW VOLTAGE

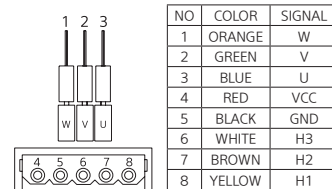

HIGH VOLTAGE

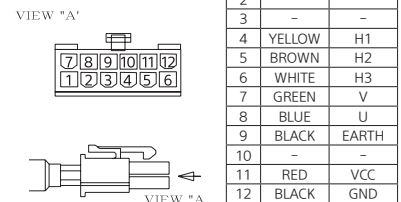

SPECIFICATION

| Model | Output (W) | Voltage (V) | At Rated Load | | | Weight (kg) |
|-------------|------------|-------------|---------------|-----------------|-------------|-------------|
| | | | Speed (rpm) | Torque (kgf.cm) | Current (A) | |
| HBM6-6024A | 60 | 24 | 3000 | 2.0 | 4.00 | 0.64 |
| HBM6-31024A | 60 | 310 | 3000 | 2.0 | 0.35 | 0.64 |