

□ 80 100W



FEATURES

- Minimize vibration and noise
- Minimize cogging load
- Protection against heat
- A variety of drive controller option

DIMENSIONS

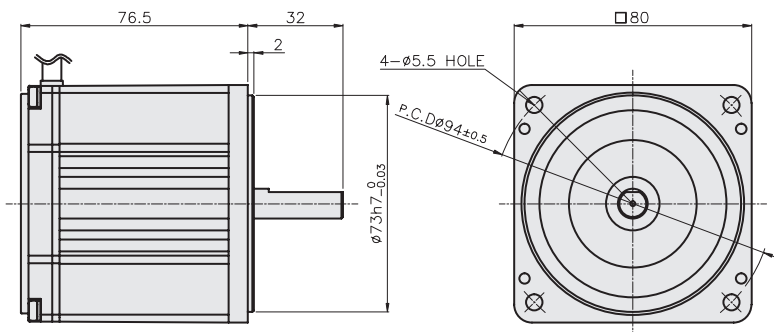

CHARACTERISTIC CURVE

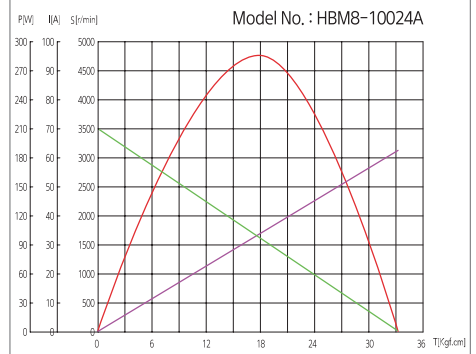

MOTOR OUTPUT SHAFT

D-CUT TYPE

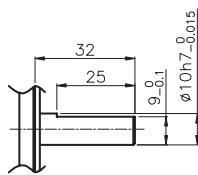

CIRCUIT DIAGRAM

LOW VOLTAGE

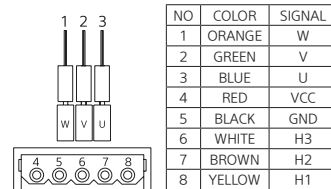

HIGH VOLTAGE

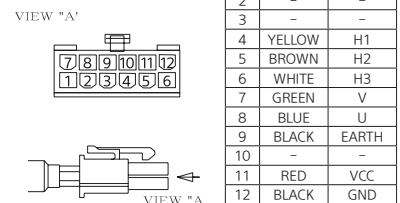

SPECIFICATION

Model	Output (W)	Voltage (V)	At Rated Load			Weight (kg)
			Speed (rpm)	Torque (kgf.cm)	Current (A)	
HBM8-10024A	100	24	3000	3.2	6.0	1.6
HBM8-100310A	100	310	3000	3.2	0.6	1.6