

STANDARD TYPE BLDC GEARED MOTOR

□ 80 Gear Ratio : 1/5 ~ 1/200



FEATURES

- Minimize vibration and noise
- Minimize cogging load
- Protection against heat
- A variety of drive controller option

DIMENSIONS

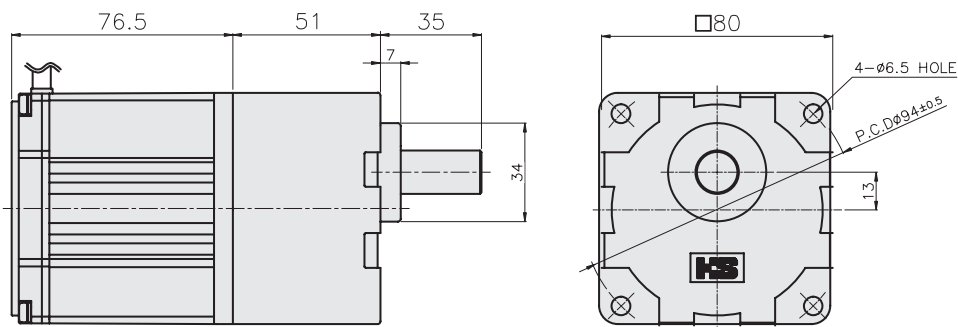

MOTOR OUTPUT SHAFT

	KEY TYPE HGK8-()K	KET TYPE
TYPE		

Maximum permissible torque of Gear Head

Model	Gear Ratio		5	10	15	20	30	50	100	200
Geared Motor: HBGM8-10024A HBGM8-100310A	Motor Speed	200~2500rpm	40~500	20~250	13.4~167	10~125	6.6~83	4~50	2~25	1~12.5
		3000rpm	600	300	200	150	100	60	30	15
Gear Head: HGK8-()	Torque	N·m(kgf·cm)	0.9(9)	1.8(18)	2.7(27)	3.6(36)	5.2(52)	8.6(86)	16(160)	16(160)
			0.45(4.5)	0.9(9)	1.4(14)	1.8(18)	2.6(26)	4.3(43)	8.6(86)	16(160)

■ Green color indicates that the output shaft of the geared motor rotates in the same direction as the output shaft of the motor. Others indicate rotation in the opposite direction.