

□ 90 100W, 200W

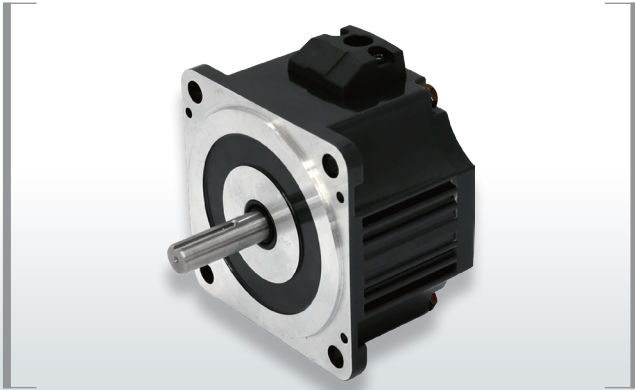

**FEATURES**

- Minimize vibration and noise
- Minimize cogging load
- Protection against heat
- A variety of drive controller option

**DIMENSIONS**

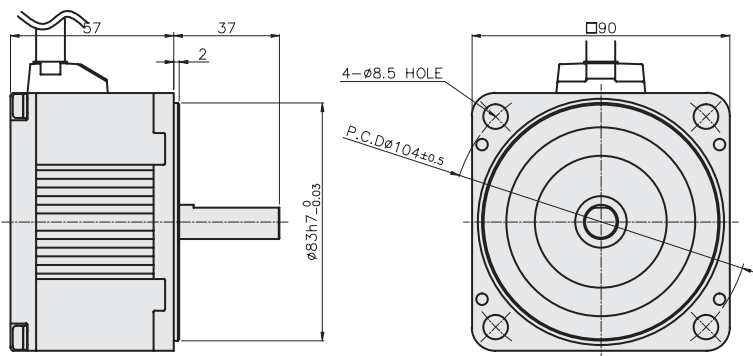

**CHARACTERISTIC CURVE**



**MOTOR OUTPUT SHAFT**

**D-CUT TYPE**

TYPE

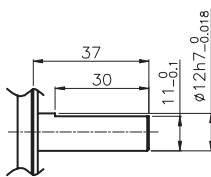

**CIRCUIT DIAGRAM**

**LOW VOLTAGE**

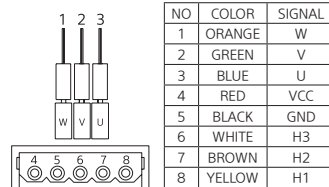

**HIGH VOLTAGE**

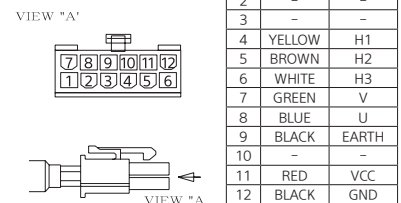

**SPECIFICATION**

Model	Output (W)	Voltage (V)	At Rated Load			Weight (kg)
			Speed (rpm)	Torque (kgf.cm)	Current (A)	
HBM9-10024A	100	24	3000	3.2	6.0	1.3
HBM9-100310A	100	310	3000	3.2	0.6	1.3
HBM9-20024A	200	24	3000	6.4	12.0	1.3
HBM9-200310A	200	310	3000	6.4	1.20	1.3