

SQUARE TYPE □90 100W

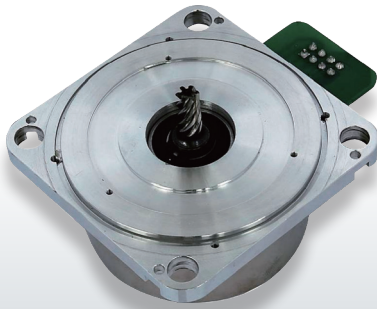

FEATURES

- Small size Flat design
- Low noise & High torque
- Fast response

DIMENSIONS

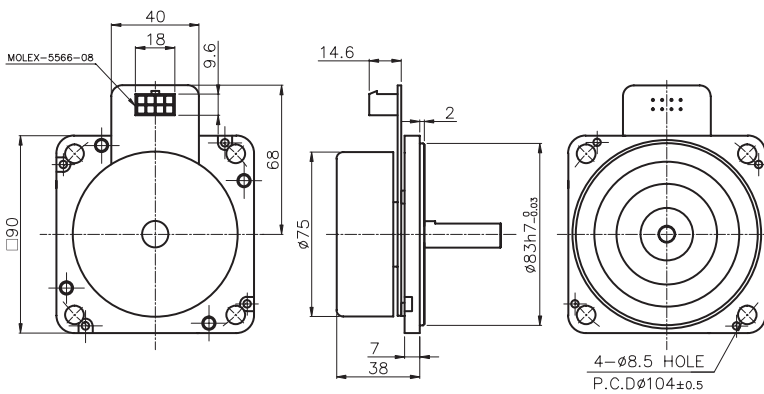

CIRCUIT DIAGRAM

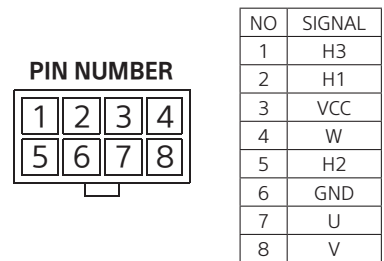

MOTOR OUTPUT SHAFT

	D-CUT TYPE	GEARED TYPE	KEY TYPE
TYPE			

SPECIFICATION

Model	Output (W)	Voltage (V)	At Rated Load			Weight (kg)
			Speed (rpm)	Torque (kgf.cm)	Current (A)	
HBOM9-10024A	100	24	3000	3.2	6.00	0.70
HBOM9-100310A	100	310	3000	3.2	0.60	0.70