

# □ HOLLOW SHAFT(FLAT TYPE) GEAR HEAD & DLDC MOTOR UNIT



100W, 200W /  
Gear Ratio 1/5 ~ 1/200

## FEATURES

- Saving of installation space
- High Strength gearhead
- Low Noise
- A variety of drive controller option

## DIMENSIONS

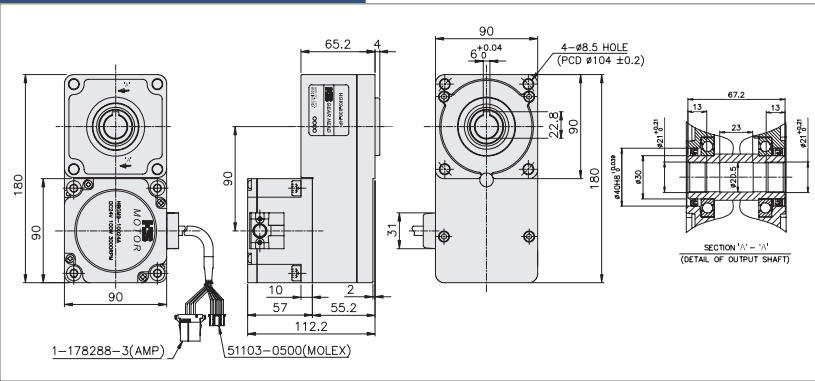

## CIRCUIT DIAGRAM

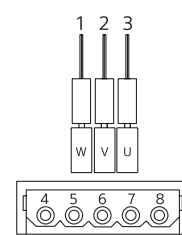

NO	COLOR	SIGNAL
1	ORANGE	W
2	GREEN	V
3	BLUE	U
4	RED	VCC
5	BLACK	GND
6	WHITE	H3
7	BROWN	H2
8	YELLOW	H1

## SPECIFICATION

Model	Output (W)	Voltage (V)	At Rated Load		
			Speed (rpm)	Torque (kgf.cm)	Current (A)
HBGM9-10024A	100	24	3000	3.4	6.0
HBGM9-20024A	200	24	3000	6.4	12

## MOTOR OUTPUT SHAFT

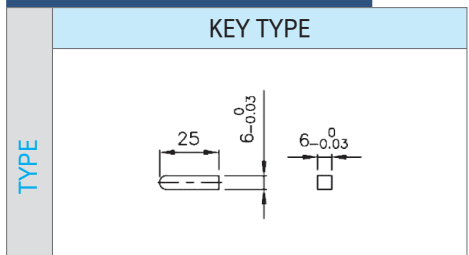

## Maximum permissible torque of Gear Head

Model	Gear Ratio		5	10	15	20	30	50	100	200
Geared Motor : HBGM9-10024A HBGM9-100310A	Speed (No Load)	rpm	600	300	200	150	100	60	30	15
	Torque	N·m	1.46	2.92	4.37	5.83	8.75	14.58	29.15	58.30
kgf.cm		14.6	29.2	43.7	58.3	87.5	145.8	291.5	583.0	
Geared Motor : HBGM9-20024A HBGM9-200310A	Speed (No Load)	rpm	600	300	200	150	100	60	30	15
	Torque	N·m	2.74	5.49	8.23	10.97	16.46	27.44	54.87	68
kgf.cm		27.4	54.9	82.3	109.7	164.6	274.4	548.7	680	