

HSG POWERFUL GEARHEAD MOTOR

□ 60 Gear Ratio : 1/5 ~ 1/200



FEATURES

- Gear Ratios optimized for BLDC motor
- Minimize vibration and noise
- Minimize cogging load
- A wide range of applications

DIMENSIONS

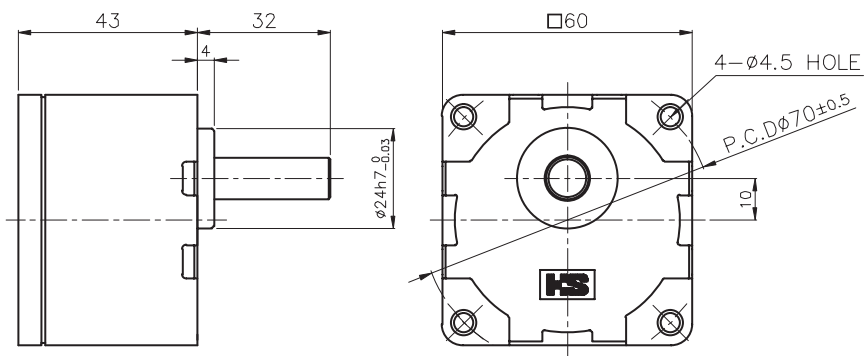

GEAR HEAD OUTPUT SHAFT

	KEY TYPE HGK6-()K	KEY SPEC
TYPE		

Maximum permissible torque of Gear Head

Model	Gear Ratio		5	10	15	20	30	50	100	200
Geared Motor: HBGM6-6024A HBGM6-60310A	Motor Speed	200~2500rpm	40~500	20~250	13.4~167	10~125	6.6~83	4~50	2~25	1~12.5
		3000rpm	600	300	200	150	100	60	30	15
Gear Head: HGK6-()	Torque	N·m(kgf·cm)	0.54(5.4)	1.1(11)	1.6(16)	2.2(22)	3.1(31)	5.2(52)	6(60)	6(60)
			0.27(2.7)	0.54(5.4)	0.81(8.1)	1.1(11)	1.5(15)	2.6(26)	5.2(52)	6(60)

- Green color indicates that the output shaft of the geared motor rotates in the same direction as the output shaft of the motor. Others indicate rotation in the opposite direction.