

□ 90 Gear Ratio : 1/5 ~ 1/200



FEATURES

- Saving of installation space
- High Strength gearhead
- Low Noise

DIMENSIONS

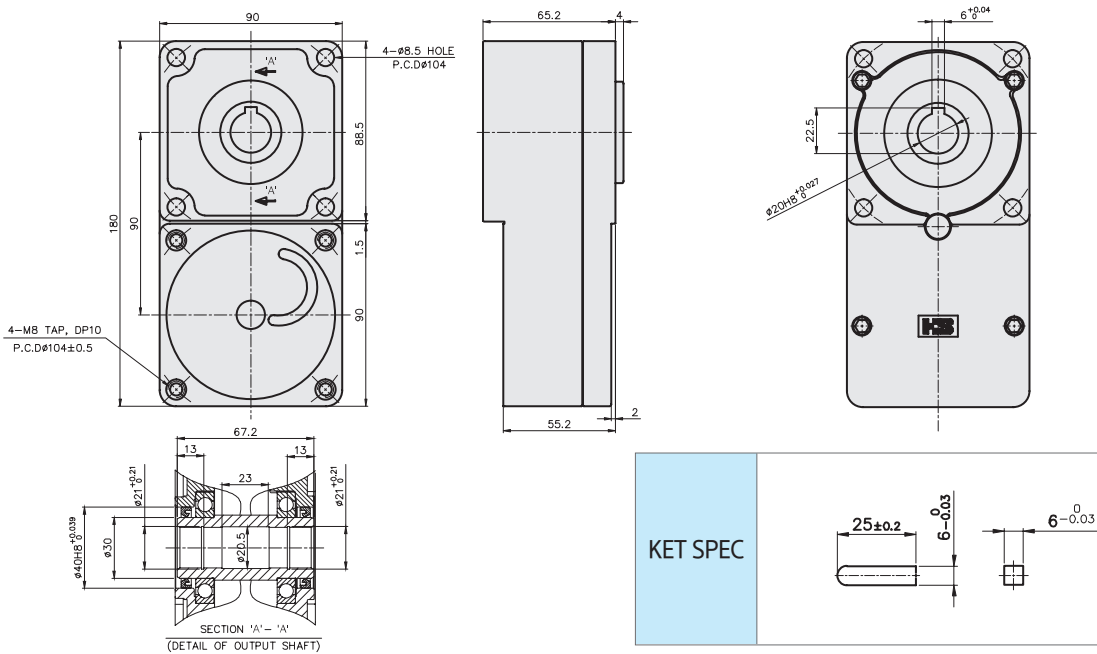

Maximum permissible torque of Gear Head

Model	Gear Ratio		5	10	15	20	30	50	100	200
Geared Motor: HBGM9-10024A HBGM9-100310A	Speed (No Load)	rpm	600	300	200	150	100	60	30	15
	Torque	N·m	1.46	2.92	4.37	5.83	8.75	14.58	29.15	58.30
kgf·cm		14.6	29.2	43.7	58.3	87.5	145.8	291.5	583.0	
Geared Motor: HBGM9-20024A HBGM9-200310A	Speed (No Load)	rpm	600	300	200	150	100	60	30	15
	Torque	N·m	2.74	5.49	8.23	10.97	16.46	27.44	54.87	68
68		27.4	54.9	82.3	109.7	164.6	274.4	548.7	680	